

Bourdon Tube Pressure Gauges

Bayonet Ring Case Stainless Steel

RCh
RChG

Standard Versions

Information on general and metrological features (load limits / temperature limitations) and standard pressure ranges / scale divisions can be found in model overview 1000.

Accuracy (EN 837-1)

Class 1.0

Case

Bayonet ring, 1.4301 (304 stainless steel)

Case Protection Type (EN 60 529 / IEC 529)

IP 54

IP 65 for model RChG 100 and

model RChG 160 (pressure ranges ≥ 2.5 bar and above)

Blow-out Device

Model RCh Blow-out plug in the back of the case, 1" (\varnothing 25mm)

Model RChG 100 Blow-out plug in the back of the case, 1½" (\varnothing 40mm)

Model RChG 160 Blow-out device at the top of the case coverage

Case Ventilation

Model RChG 100 without ventilation, but with internal pressure compensation by pressure equalizing membrane.

Model RChG 160 by blow-out device.

Case Filling

for model RChG: glycerine

Nominal Case Size

Model RCh: 100, 160, 250 (mm) (4", 6", 10")

Model RChG: 100, 160 (mm) (4", 6")

Wetted Parts

Type -3: Connection: 1.4571 (316 stainless steel)

Bourdon tube: 1.4571 (316 stainless steel),
argon arc welding,
 ≤ 40 bar (600 psi) c-form
 ≥ 60 bar (800 psi) helical
1,600 bar (20,000 psi) NiFe-alloy, helical

Type -1: Connection: brass

Bourdon tube: ≤ 40 bar (600 psi) bronze, c-form
soft-soldered
 ≥ 60 bar (800 psi) 1.4571 (316 stainless steel), helical
silver brazed

Case Configuration

Connection: screwed

Position of the connection: bottom connection,
optional lower back connection (r)
without, optional back flange for
mounting device: surface mounting (Rh) / front flange
for panel mounting (Fr), see page 2

Pressure Ranges (EN 837-1)

0-0.6 bar (0-10 psi) to 0-1,600 bar (0-20,000 psi) for type -3

0-0.6 bar (0-10 psi) to 0-1,000 bar (0-15,000 psi) for type -1

Process Connection

G ½ B (½" BSP)

Window

Laminated safety glass for type -3

Instrument glass for type -1

Movement

Stainless steel for type -3

Brass/German silver for type -1

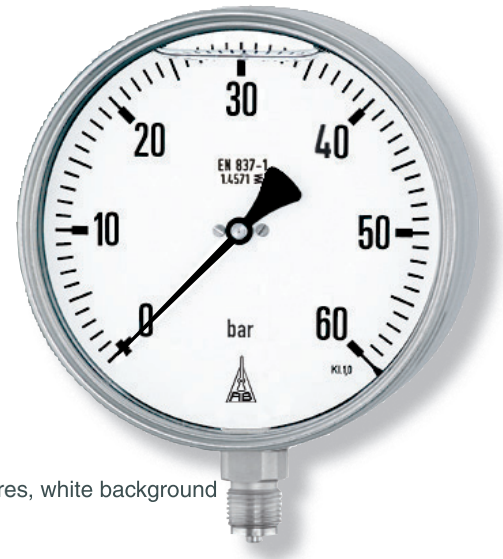

Dial

Aluminum, black figures, white background

Pointer

Aluminum, black

Safety Category according to EN 837-1

NCS 100 (4"): S1 pressure gauges with blow-out device

Ordering Information, Standard Pressure Ranges, Options:

see pages 3 and 4

Special Versions and further Options among others

- Other process connections upon request, e.g. high pressure connection with external male thread (0-60 bar / 0-800 psi and above)
- Other pressure ranges and / or special scales, e.g. double scale bar/psi, coloured fields or areas, dial inscriptions, negative scale etc.
- Version as refrigeration gauge with temperature scale (NCS 100)
- Stationary pointer or drag indicator with window made of polycarbonate or laminated safety glass upon request (not for NCS 250)
- Case parts 1.4404 (316 L stainless steel) upon request
- Increased case protection type, e.g. IP 65 without case filling, upon request
- Other case fillings upon request
- Model RChG 100-3 and 160-3 for ambient temperatures down to -40 °C (-40 °F). Our recommendation for ambient temperatures below -20 °C (-4 °F); pressure gauges with crimped-on ring case models RChg resp. RChG
- Versions for medium temperatures up to 300 °C (572 °F), but without case filling upon request (not NCS 250)
- Position of connection radial at 3 o'clock, 9 o'clock or 12 o'clock (others upon request) or other than vertical installation (90°):
 - for models without case filling and for filled models with pressure equalizing membrane;
 - for filled models without pressure equalizing membrane upon request
- GOST-version for Russia, Ukraine, Kazakhstan
- Sour gas-resistant version according to NACE

Accessory:

Chemical seals: see catalogue-heading 7

Electrical: limit switch contact assembly DS 1291 and catalogue-heading 9.1

Other accessory: see catalogue-heading 11



Sales and Export South, West, North

ARMATURENBAU GmbH

Manometerstraße 5 • D-46487 Wesel - Ginderich
Tel.: +49 (0) 28 03 / 91 30-0 • Fax: +49 (0) 28 03 / 10 35
armaturenbaum.com • mail@armaturenbaum.com

LEYRO INSTRUMENTS SL

Avda. Somosierra 24
San Sebastián de los Reyes, Madrid
Tel.: +34 912 835 502
info@leyro.net
www.leyroinstruments.com

leyro

Bottom connection | **Lower back connection**

No mounting device

(no additional code letter)

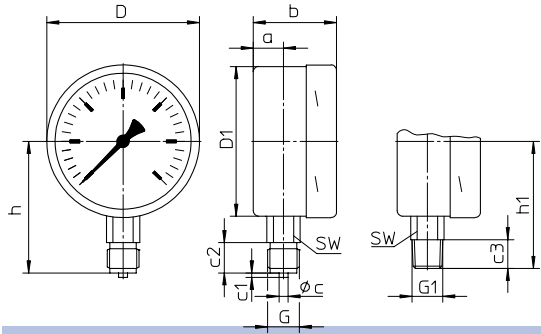

code letter: r

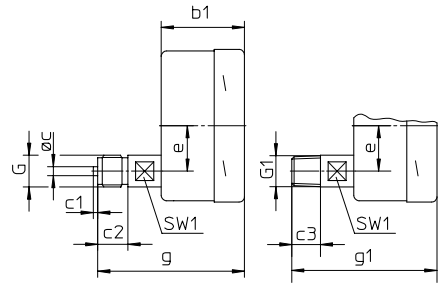

Back flange for surface mounting

code letters: **Rh**

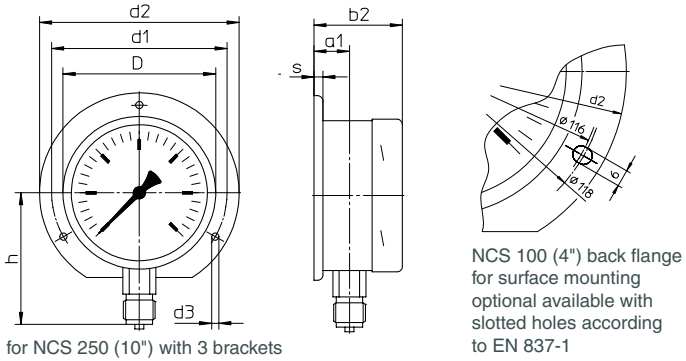

code letters: **rRh**

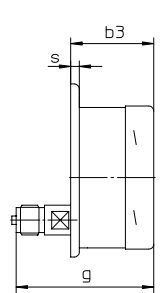

(available upon request, but according to EN 837-1 not recommended)

for NCS 250 (10") with 3 brackets

Front flange for panel mounting

code letters: **Fr**

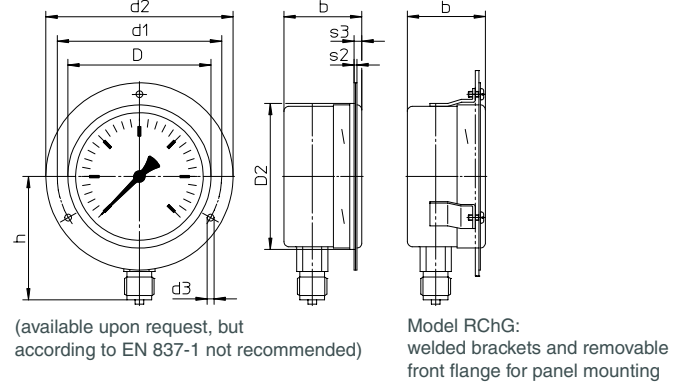

code letters: **rFr**

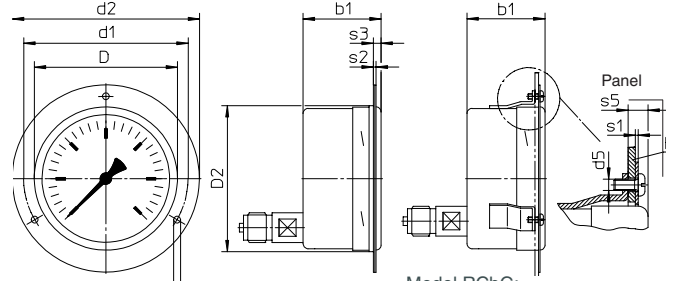

Model RChG: welded brackets and removable front flange for panel mounting

recommended panel cut out for NCS 100 (4") Ø 104 ± 0.5 mm (0.02")
NCS 160 (6") Ø 164 ± 0.5 mm (0.02")
NCS 250 (10") Ø 254 ± 0.5 mm (0.02")

Dimensional data (mm / inches) and weights (kg / lb)

NCS	a	a1	b	b1	b2	b3	c	c1	c2	c3	D	D1	D2	d1	d2	d3	d5	e	G	G1	g	g1	h ^{±1}	h1 ^{±1}
100 4"	20 .79	23.5 .93	55 2.17	55 2.17	58.5 2.3	58.5 2.3	6 .24	3 .12	20 .79	19 .75	101 3.98	99 3.9	103 4.06	116 4.57	132 5.2	4.8 .19	M4	30 1.18	G ½ B ½" BSP M 20 x 1.5	½" NPT	97 3.82	96 3.78	87 3.43	84 3.31
160 6"	15.5 .61	19 .75	51 2.01	51 2.01	54 2.13	54 2.13	6 .24	3 .12	20 .79	19 .75	161 6.34	159 6.26	163 6.42	178 7.01	196 7.72	5.8 .23	M5	30 1.18	G ½ B ½" BSP M 20 x 1.5	½" NPT	92.5 3.64	91.5 3.6	115 4.53	114 4.49
250 10"	15.5 .61	17.5 .69	58 2.28	58 2.28	60 2.36	60 2.36	6 .24	3 .12	20 .79	19 .75	251 9.88	249 9.8	-	270 10.63	285 11.22	5.8 .23	-	52 2.05	G ½ B ½" BSP M 20 x 1.5	½" NPT	97 3.82	96 3.78	165 6.5	164 6.46

Blow-out device

Blow-out device for model RChG 160
Pressure range ≤ 1.6 bar (23.20 psi) blow-out device no.5
≥ 2.5 bar (30 psi) blow-out device no.3

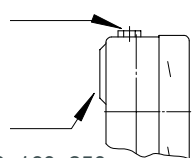

Blow-out plug
Ø 1" (25 mm) for models RCh 100, 160, 250
Ø 1½" (40 mm) for model RChG 100
with pressure equalizing membrane

s	s1	s2	s3	s5	SW	SW1	approx. weight ¹⁾	
							RCh	RChG
6	1	2	5.5	7	22	17	0.60	0.95
.24	.04	.08	.22	.28	.87	.67	1.33	2.1
6	1.5	2.5	6	8	22	17	1.10	1.95
.24	.06	.1	.24	.31	.87	.67	2.43	4.3
.08	-	2	8.5	-	22	17	2.10	-
		.08	.33	-	.87	.67	4.63	-

¹⁾ Information for version without mounting device

Basic Model:		Bourdon Tube Pressure Gauge, Bayonet Ring Case	RCh	
Case Filling:	without		without code letters	
	glycerine		G	
	fillable version		(G)	
Nominal Case Size:	case- Ø 100,160, 250 (mm) (4", 6", 10")		100, 160, 250	
Wetted Material:	copper alloy		-1	
	stainless steel		-3	
	Monel, 0-0.6 bar (10 psi) to 0-1,000 bar (15,000 psi), movement stainless steel, laminated safety glass, bourdon tube Monel argon arc welding, ≤ 40 bar (0-600 psi) c-form, ≥ 60 bar (1,000 psi) helical, bottom connection, optional r		-6	
Case Configuration:	case / connection	screwed	without code letters	
		welded (only type -3, not NCS 250)	v	
	position of the connection:	bottom connection	without code letters	
	lower back connection	r		
mounting device:	without		without code letters	
	back flange for surface mounting		Rh	
	front flange for panel mounting		Fr	
Pressure Ranges:	-1,200 – 0 mbar	30" Hg vac. – 0 psi		
	-0.6 – 0 bar			
	-1 – 0 bar			
	-1 – 0.6 bar	30" Hg vac. – 15 psi		
	-1 – 1.5 bar	30" Hg vac. – 30 psi		
	-1 – 3 bar	30" Hg vac. – 60 psi		
	-1 – 5 bar	30" Hg vac. – 100 psi		
	-1 – 9 bar	30" Hg vac. – 160 psi		
	-1 – 15 bar	30" Hg vac. – 200 psi		
	0 – 0.6 bar	0 – 10 psi		
	0 – 1 bar	0 – 15 psi		
	0 – 1.6 bar			
	0 – 2.5 bar	0 – 30 psi		
	0 – 4 bar	0 – 60 psi		
	0 – 6 bar	0 – 100 psi	e. g. 0-6 bar	
	0 – 10 bar	0 – 160 psi		
	0 – 16 bar	0 – 200 psi		
	0 – 25 bar	0 – 300 psi		
	0 – 40 bar	0 – 600 psi		
	0 – 60 bar	0 – 800 psi		
	0 – 100 bar	0 – 1,500 psi		
	0 – 160 bar	0 – 2,000 psi		
	0 – 250 bar	0 – 3,000 psi		
	0 – 400 bar	0 – 5,000 psi		
	0 – 600 bar	0 – 10,000 psi		
	0 – 1,000 bar	0 – 15,000 psi		
	0 – 1,600 bar	for type -3 0 – 20,000 psi		
Process Connection:	standard thread	G ½ B (½"BSP)	G ½ B	
	options:	½" NPT	-1 and -6 max. 0-1,000 bar; -3 max. 0-1,600 bar	½" NPT
		M 20 x 1.5		M 20 x 1,5
		G ¼ B (¼"BSP) ¹⁾	-1 max. 0- 600 bar; -3 and -6 max. 0-1,000 bar	G ¼ B
		¼" NPT ¹⁾		¼" NPT
		M 12 x 1.5 ¹⁾		
		high pressure connection female thread (0-60 bar and above) for ¼" tube, with 60° cone		
	M 16 x 1.5		HD-Anschluss M 16x1,5	
	9/16" - 18 UNF		HD-Anschluss 9/16" - 18 UNF	
Options:	see page 4			
Example:	RCh 100-3 rFr, 0-6 bar, G ½ B			

¹⁾ not NCS 250

Basic Model:	Bourdon Tube Pressure Gauge, Bayonet Ring Case	RCh
Model Code:		see page 3
Options:	adjustable pointer, aluminum mechanism red mark on the dial plastic clip red or green external at the bayonet ring (not NCS 250) stationary red pointer on the dial adjustable when removable ring stationary red pointer adjusting mechanism brass, nickelplated screwed with window made of acrylic glass adjustable externally removable key non-removable key adjusting mechanism stainless steel screwed with window made of acrylic glass adjustable externally removable key non-removable key min. - or max. - drag indicator adjusting mechanism brass, nickelplated screwed with window made of acrylic glass 2.5 bar (30 psi) and above adjustable externally removable key non-removable key adjusting mechanism stainless steel screwed with window made of acrylic glass adjustable externally removable key non-removable key receiver gauge 0.2-1 bar, scale 0-100% linear square indication accuracy grade 2A ($\pm 0.5\%$) according to ASME B 40.1 ¹⁾ special adjustment (reference points = odd values, e. g. 100 KN = 8.735 bar) window laminated safety glass for type -1 acrylic glass (PMMA) polycarbonate (PC) movement stainless steel for type -1 (for -3 and -6 standard) silicone damped brass / polyacetal case ventilation no. 22 for outdoor installation case polished bayonet ring polished density examination of the measuring unit with helium leak detection up to 10^{-9} mbar l/s for types -3 and -6 wetted parts, free of grease and oil, up to 0-600bar (0-10,000 psi) adjustment ≤ 250 bar (3,000 psi) with dry air, ≥ 400 bar (5,000 psi) with distilled water, dial marking: symbol cancelled oil can oxygen version, up to 0-600 bar ²⁾ (0-10,000 psi) free of grease and oil, additional restrictor screw in the inlet port, orifice $\varnothing 0.3$ mm (0.01"), dial inscription: oxygen no version according to EN 837-1 ³⁾ silicone-free version version: dial marking: symbol German Lloyd or Russian Sea Register NCS 100 / 160 copy of the certificate upon request restrictor screw in pressure inlet port orifice $\varnothing 0.8$ mm (0.03") orifice $\varnothing 0.6$ mm (0.02") (not Monel) material: as process connection brass, stainless steel or Monel orifice $\varnothing 0.3$ mm (0.01") (not Monel) measuring point marking stainless steel-plate 12 mm x 55 mm (0.47" x 2.17"), wire mounting or sticker on case coverage deflagration volume-protection Adapt FS version 5 according to DS 11001	(order at the moment still as cleartext)

Special Versions: Please describe your requirements clearly

¹⁾ for pressure ranges $\leq 10,000$ psi
²⁾ for instruments without case filling

³⁾ EN 837-1 in connection with oxygen version requires safety category S3

Technical changes, replacement of materials and errors excepted.